



ZigBee- Ready SoC RF Transceiver Modules

Table of Content

General Description.....	2
Applications.....	2
Features.....	2
Absolute Maximum Ratings.....	3
Recommended Operating Conditions.....	3
Electrical Specifications.....	3
Introduction.....	5
Typical Application Block.....	5
Pin Assignment.....	6
Block Diagram.....	8
Circuit Description.....	8
SIF Module Programming and Debug Interface.....	9
Power Management.....	9
RF Frequency, Output Power Levels and Data Rates.....	10
Antenna Design Considerations.....	11
PCB Layout Recommendations.....	13
Mechanical Dimensions.....	14
Ordering Information.....	14
Document Revision History.....	14



CT-EM250 ZigBee-Ready RF Transceiver Modules

ZigBee- Ready SoC RF Transceiver Modules

General Description

The CT-EM250 SoC RF Transceiver Modules is a compact surface mounted module specially designed for Ember's ZigBee™ protocol stack for wireless networks, EmberZNet, based on IEEE 802.15.4 standard in the 2.4GHz world-wide ISM band. It provides 16 channels and compliant PHY and MAC layers. The complete module is only 20.32 x 25.52 x 3 mm (integrated antenna version) and 20.32 x 19.53 x 3 mm (External Antenna version). They both integrate a 2.4GHz, IEEE 802.15.4-compliant transceiver with a 16-bit XAP2b microprocessor. They consist of integrated Flash and RAM memory and peripherals. A number of peripherals such as GPIO, UART, SPI, I2C, ADC, and general purpose timers are integrated to support user-defined applications.

Applications

Home automation & building control

Home appliances & alarms

Monitoring of remote systems

Security systems & lighting controls

Sensor data capture in embedded networks



Features

- Complete ZigBee-ready module with or without integrated antenna
- IEEE 802.15.4 compliant PHY and MAC layer
- 12MHz XAP2b 16-bit microcontroller core
- 128kB Flash and 5kB RAM, emulation EEPROM
- 17 GPIO , 4 channel 12 bit ADC
- UART, SPI, I²C and debug interfaces
- External 32.768 kHz real time clock or internal RC oscillator for timer
- High performance direct sequence spread spectrum (DSSS) RF transceiver
- 16 channels in the 2.4 GHz ISM band
- on-chip regulator for 2.1-3.6V operation, two sleep low power modes



CT-EM250 ZigBee-Ready RF Transceiver Modules

Absolute Maximum Ratings

Parameter	Test Conditions	Min.	Max.	Unit
Regulator voltage (VDD_PADS)		- 0.3	3.6	V
Voltage on any GPIO[16:0], SIF_CLK, SIF_MISO, SIF_MOSI, nSIF_LOAD, OSC32A, OSC32B, nRESET,		- 0.3	VDD_PADS+ 0.3	V
Storage temperature		- 40	+ 140	°C

Under no circumstances should the absolute maximum ratings given above be violated. Stress exceeding one or more of the limiting values may cause permanent damage to the device.

Recommended Operating Conditions

Parameter	Test Conditions	Min.	Typ.	Max.	Unit
Regulator input voltage (VDD_PADS)		2.1		3.6	V
Core input voltage (VDD_24MHZ, VDD_VCO, VDD_RF, VDD_IF, VDD_PADSA, VDD_FLASH, VDD_PRE, VDD_SYNT, VDD_CORE)		1.7	1.8	1.9	V
Temperature range		- 40		+ 85	°C

Electrical Specifications

T=25 °C, VCC = 3.0V, fo=2450Mhz, if nothing else stated.

Parameter	Min.	Typ.	Max	Unit	Condition / Note
Operating frequency	2400		2485	MHz	Programmable in 5 MHz steps for IEEE 802.15.4 compliance
Number of channels		16			For IEEE 802.15.4 compliance
Channel spacing		5		MHz	For IEEE 802.15.4 compliance
Input/output impedance		50		Ohm	
Data rate		250		kbit/s	
DSSS chip rate		2		Mc/s	
Frequency stability			+/-40	ppm	
Transmit power	-32		5	dBm	Programmable from firmware
Harmonics					
2nd harmonic			TBD	dBm	
3rd harmonic			TBD	dBm	



CT-EM250 ZigBee-Ready RF Transceiver Modules

Parameter	Min.	Typ.	Max	Unit	Condition / Note
Spurious emission, TX 30 – 1000 MHz 1-12.75 GHz 1.8-1.9 GHz 5.15-5.3 GHz			TBD TBD TBD TBD	dBm	Complies with EN 300 328, EN 300 440, FCC CRF47 Part 15 and ARIB STD-T66
Sensitivity		-98		dBm	PER = 1% Boost Mode
Adjacent channel rejection +/-5 MHz		35/35		dB	IEEE 802.15.4 signal at - 82dBm
Adjacent channel rejection +/-10 MHz		40/40		dB	IEEE 802.15.4 signal at - 82dBm
Co-channel rejection		-6		dB	IEEE 802.15.4 signal at - 82dBm
Spurious emission, RX 30 -1000 MHz 1-12.75 GHz			TBD TBD	dBm	Complies with EN 300 328, EN 300 440, FCC CRF47 Part 15 and ARIB STD-T66
Supply voltage	2.1		3.6	V	
Current consumption, RX		36		mA	Max RX sensitivity (boost mode)
Current consumption, TX		36		mA	At max. TX power (+ 5dBm boost)
Quiescent current, Mode1		1.0		µA	including internal RC oscillator
Quiescent current, Mode2		1.5		µA	including 32.768k oscillator
Flash memory		128		KB	
RAM memory		5		KB	
Simulated EEPROM memory		8		KB	
MCU clock frequency		12		MHz	
RC OSCILATOR FREQUENCY		10		KHZ	
MCU low frequency crystal		32.768		kHz	

Introduction

The CT-EM250 series of modules are specially designed for ZigBee application. They provide a fast jump start design for system integrators or electronic designers wishing to use ZigBee wireless technologies. The module contains qualified RF hardware and enough processor power to run the EmberZNet stack or other ZigBee network stack (depending on version), making it a powerful platform for building wireless networking products. ZigBee Coordinators (ZC), ZigBee Routers (ZR), and ZigBee End Devices (ZED) are all supported and are programmed onto the module together with a custom application. Minimal RF design experience is need to use CT-EM250 modules.

Typical application block

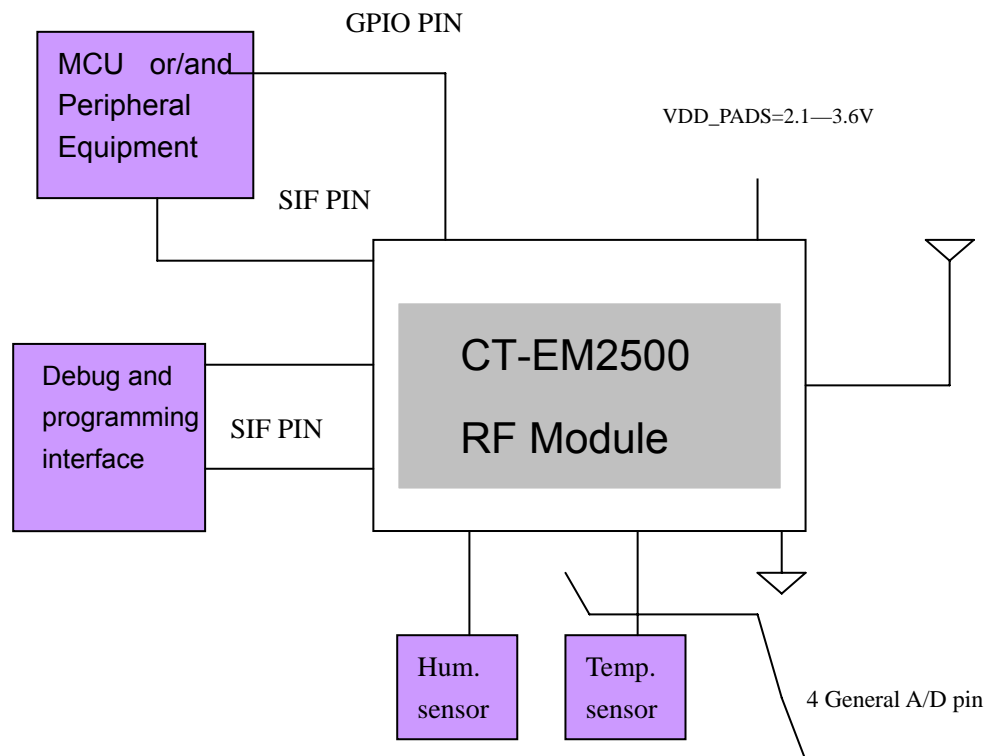
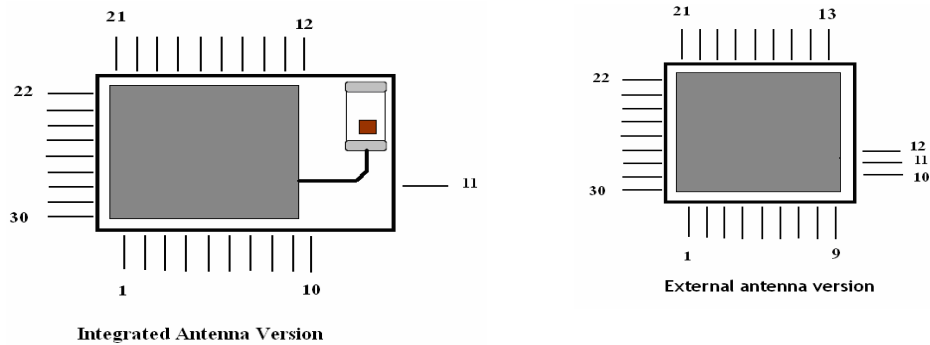

Figure 1 Example of application block

Pin Assignment



CT-EM250 ZigBee-Ready RF Transceiver Modules



Pin Description

Pin#	Signal	Direction	Description
1	SIF_MISO	O	Serial interface, master in/slave out
2	SIF_MOSI	I	Serial interface, master out/slave in
3	SIF_LOADB	I/O	Serial interface, load strobe (open-collector with internal pull-up)
4	GND	Ground	Ground supply
5	GPIO16	I/O	Digital I/O Enable GPIO16 with GPIO_CFG[3]
6	GPIO15	I/O	Digital I/O Enable GPIO15 with GPIO_CFG[2]
7	GPIO14	I/O	Digital I/O Enable GPIO14 with GPIO_CFG[1]
8	GPIO13	I/O	Digital I/O Enable GPIO13 with GPIO_CFG[0]
9	GND	Ground	Ground supply
10	GND	Ground	Ground supply
11	ANT	I/O	receiver input/transmitter output
12	GND	Ground	Ground supply
13	nRESET	I	Active low chip reset (internal pull-up)
14	OSCB	I/O	24MHz crystal oscillator or left open when using external clock input on OSCA
15	OSCA	I/O	24MHz crystal oscillator or external clock input
16	VBRD	Power	Pads supply (2.1-3.6V)
17	GPIO11	I/O	Digital I/O Enable GPIO11 with GPIO_CFG[7:4]
18	GPIO12	I/O	Digital I/O Enable GPIO12 with GPIO_CFG[7:4]
19	GPIO0	I/O	Digital I/O Enable GPIO0 with GPIO_CFG[7:4]
20	GPIO1	I/O	Digital I/O Enable GPIO1 with GPIO_CFG[7:4]
21	GPIO2	I/O	Digital I/O



CT-EM250 ZigBee-Ready RF Transceiver Modules

			Enable GPIO2 with GPIO_CFG[7:4]
22	GPIO3	I/O	Digital I/O Enable GPIO3 with GPIO_CFG[7:4]
23	GPIO4	I/O	Digital I/O Enable GPIO4 with GPIO_CFG[12] and GPIO_CFG[8]
24	GPIO5	I/O	Digital I/O Enable GPIO5 with GPIO_CFG[12] and GPIO_CFG[9]
25	GPIO6	I/O	Digital I/O Enable GPIO6 with GPIO_CFG[10]
26	GPIO7	I/O	Digital I/O Enable GPIO7 with GPIO_CFG[13] and GPIO_CFG[11]
27	GPIO8	I/O	Digital I/O Enable GPIO8 with GPIO_CFG[14]
28	TXD	O	UART transmit data of Serial Controller SC1 Enable SC1-4A or SC1-2 with GPIO_CFG[7:4], select UART with SC1_MODE
29	RXD	I	UART receive data of Serial Controller SC1 Enable SC1-4A or SC1-2 with GPIO_CFG[7:4], select UART with SC1_MODE
30	SIF_CLK	I	Serial interface, clock (internal pull-down)

Block Diagram

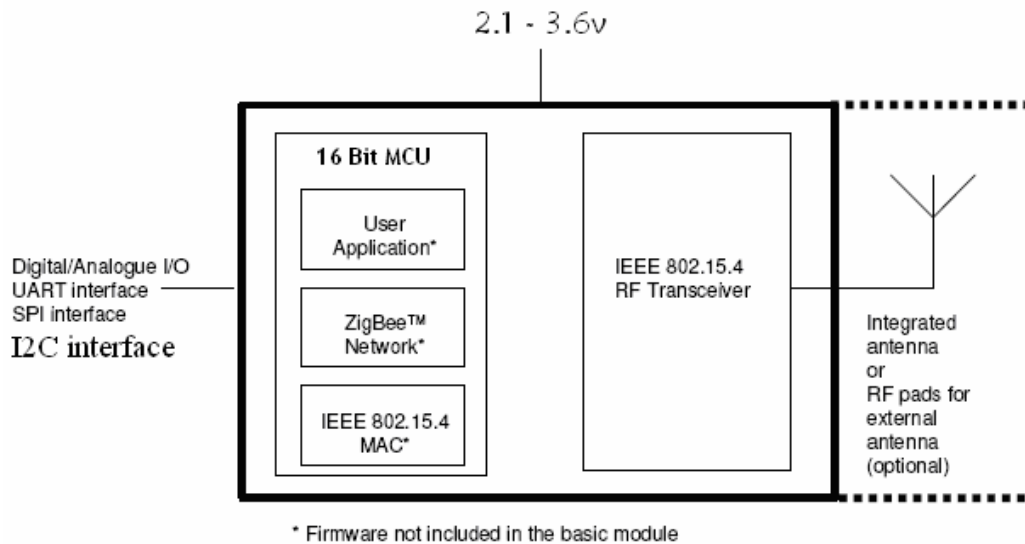

Circuit Description

The module contains an IEEE 802.15.4 compliant SoC RF transceiver, internal memory, high speed oscillator, RC oscillator and an external 32 kHz oscillator. The module is intended to run the EmberZNet ZigBee software or other ZigBee network implementation, depending on the specific version.

The application software together with the ZigBee protocol software stack can be programmed in Flash memory through the SIF module, using an evaluation board from Ember InSight Desktop.

To support user-defined applications, a number of peripherals such as GPIO, UART, SPI, I2C, ADC, and general-purpose timers are integrated. Also, an integrated voltage regulator, power-on-reset circuitry, sleep timer, and low-power sleep modes are available. The deep sleep mode draws less than 1µA (need to further verification), allowing products to achieve long battery life.

For further details on the SoC transceiver (Ember EM250), please consult the data sheet at <http://www.ember.com>



CT-EM250 ZigBee-Ready RF Transceiver Modules

SIF Module Programming and Debug Interface

SIF is a synchronous serial interface developed by Cambridge Consultants Ltd. It is the primary programming and debug interface of the CT-EM250. The SIF module allows external devices to read and write memory-mapped registers in real-time without changing the functionality or timing of the XAP2b core.

The SIF interface provides the following:

- IC production test (especially analog)
- PCB production test
- XAP2b code development
- Product control and characterization

The pins are:

- SIF_LOADB
- SIF_CLK
- SIF_MOSI
- SIF_MISO

The maximum serial shift speed for the SIF interface is 48MHz. SIF interface accesses can be initiated even when the chip is in idle and deep sleep modes. An edge on SIF_LOADB wakes the chip to allow SIF cycles.

Power Management

The CT-EM250 supports three different power modes: processor ACTIVE, processor IDLE, and DEEP SLEEP.

The IDLE power mode stops code execution of the XAP2b until any interrupt occurs or an external SIF wakeup command is seen. All peripherals including the radio continue to operate normally.

The DEEP SLEEP power mode powers off most of the module but leaves the critical chip functions, such as the GPIO pads and RAM powered by the High Voltage Supply (VDD_PADS). The module can be woken by configuring the sleep timer to generate an interrupt after a period of time, using an external interrupt, or with the SIF interface. Activity on a serial interface may also be configured to wake up the module, though actual reception of data is not re-enabled until the module has finished waking up. Depending on the speed of the serial data, it is possible to finish waking up in the middle of a byte. Care must be taken to reset the serial interface between bytes and discard any garbage data before the rest. Another condition for wakeup is general activity on GPIO pins.



CT-EM250 ZigBee-Ready RF Transceiver Modules

RF Frequency, Output Power Levels and Data Rates

The following table shows the RF channels as defined by the IEEE 802.15.4

RF channel	Frequency
11	2405 MHz
12	2410 MHz
13	2415 MHz
14	2420 MHz
15	2425 MHz
16	2430 MHz
17	2435 MHz
18	2440 MHz
19	2445 MHz
20	2450 MHz
21	2455 MHz
22	2460 MHz
23	2465 MHz
24	2470 MHz
25	2475 MHz
26	2480 MHz

The output power level can be configured in the range -32 to 5 dBm. The RF transceiver uses direct sequence spread spectrum (DSSS) with a raw data rate of 250 kbit/s. The modulation format is Offset – Quadrature Phase Shift Keying (O-QPSK). It is robust even under noisy environments when sharing the same frequency band with other applications.

The use of RF frequencies and maximum allowed RF power should according to different national regulations. The CT-EM250 is complying with the applicable regulations for the world wide 2.4GHz ISM band.

[Subject to final approval: Specifically it complies with the European Union R&TTE directive meeting EN 300 328 and EN300 440 class 2. It also meets the FCC CFR47 Part15 regulations for use in the US and the ARIB T-66 for use in Japan.]

Antenna Design Considerations

CT-EM250 provides an integrated antenna. The design should be effective for many applications requiring a compact solution containing all the critical RF parts within the module. Applications requiring better range may consider an external antenna or possibly even an external booster circuit (power amplifier).

The range testing using the integrated antenna shows a typical distance of 100 m outdoor line-of-sight (LOS). If the application is used indoors, the range will be around 10 to 30 m, depending on structure and building materials.

The module with antenna is matched for use in the 2.4 GHz band. Due to the dielectric ceramic material the antenna is shorter than a normal quarter wave antenna. However, it can still provide high radiation efficiency (typical 1 dBi). The radiating part of the antenna is located on one side of the PCB. The radiation pattern from the antenna is shown in figure 2. The maximum radiation is in the plane normal to the length axis of the antenna. For best possible omni-directional radiation the module should be oriented so that the antenna is vertical. In order to achieve best range the transmitting and receiving antenna should be oriented the same way with same polarity. Indoors reflections of the radio waves will affect the range.

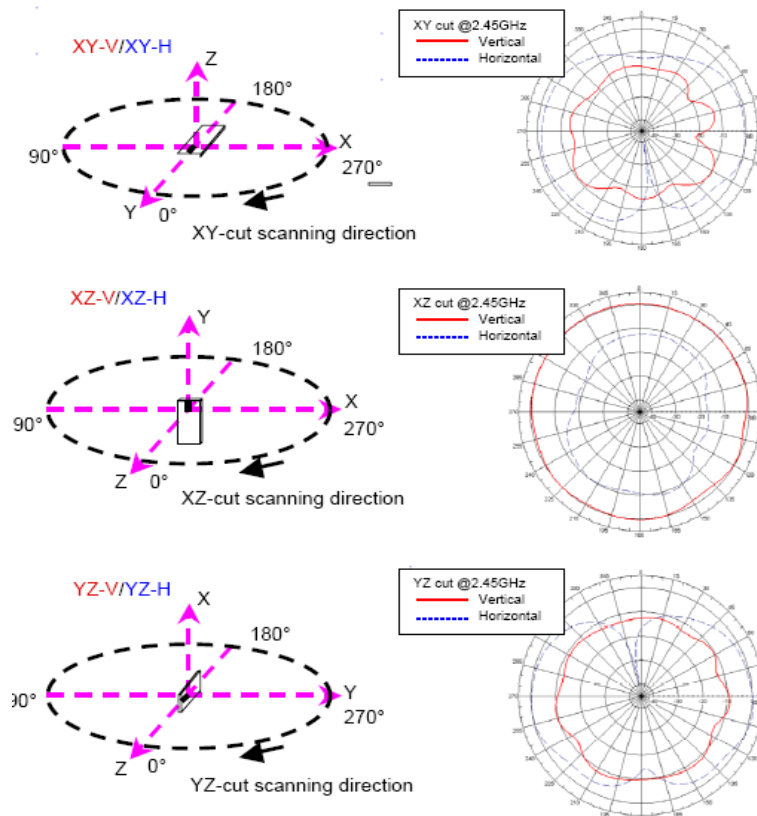

Figure 2 : Integrated chip antenna radiation pattern at different orientations



CT-EM250 ZigBee-Ready RF Transceiver Modules

The antenna should be kept away ($> 10\text{mm}$) from metallic or other conductive and dielectric materials, and should never be used inside a metallic enclosure.

Compared to lower frequencies, operation at 2.4GHz usually has a shorter LOS. However, the ZigBee mesh network topology provides a more flexible and reliable network topology to end users. The farther end device can easily be reached over a mesh network through other full function (routing) devices. Reflections from walls and other objects may give multi-path fading resulting in dead-zones. With mesh network, other nodes in the network can reach devices in dead-zones. Furthermore, in the case of any failure of a single node, the system can easily reroute to other paths. The mesh network is therefore highly recommended for increased reliability and extended coverage.

In applications where the module must be placed in a metallic enclosure, an external antenna must be used. The external antenna must match to 50 Ohm.

A PCB antenna can be made as a copper track where the ground plane is removed on the back side. The rest of the PCB board should have a ground plane as large as possible, preferably as large (in one dimension) as the antenna itself, to make it act as a reflector mirror to the antenna. A quarter-wavelength antenna on a PCB must be shorter than the wire antenna due to the influence of the dielectric material of the PCB. The length reduction depends on the PCB thickness and material, as well as how close to the edge of the board the antenna is placed. Typical reduction is to 75-90 % but specific results may vary.

The length of a quarter-wave antenna is given in the table below.

Frequency (MHz)	Length of whip antenna (cm)	Length of PCB track (cm)
2450	2.9	2.2---2.7

If, for space reasons, the track is made even shorter than the resonating quarter of wavelength, the antenna should be matched to 50 ohms using a series inductor and a shunt capacitor.



CT-EM250 ZigBee-Ready RF Transceiver Modules

PCB Layout Recommendations

For recommended layout pads for the module, please reference Mechanical Dimensions.

The area underneath the module should be covered with solder resist in order to prevent short circuiting the test pads on the back side of the module. A solid ground plane is preferred. Unconnected pins should be soldered to the pads, and the pads should be left floating. For the module with integrated antenna, the RF pad can be soldered, but the pad should not be connected further. The two ground pads (pin10 and pin12 should be grounded for all variants.)

When using the onboard chip antenna, careful attention is required to the layout of the PCB where the module is mounted. In Figure 3 a mother PCB is shown with a recommended placement of the module.

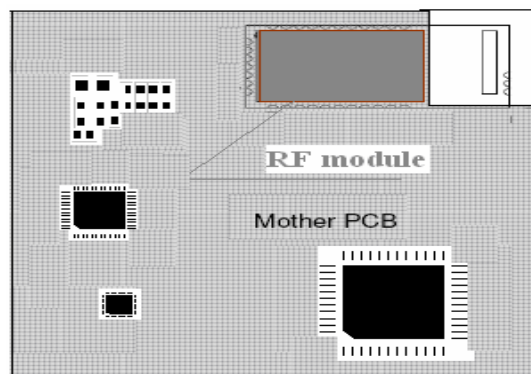

Figure 3 A recommended placement of the module on a mother PCB (Shaded area is ground-plane on mother PCB)

Mechanical Dimensions

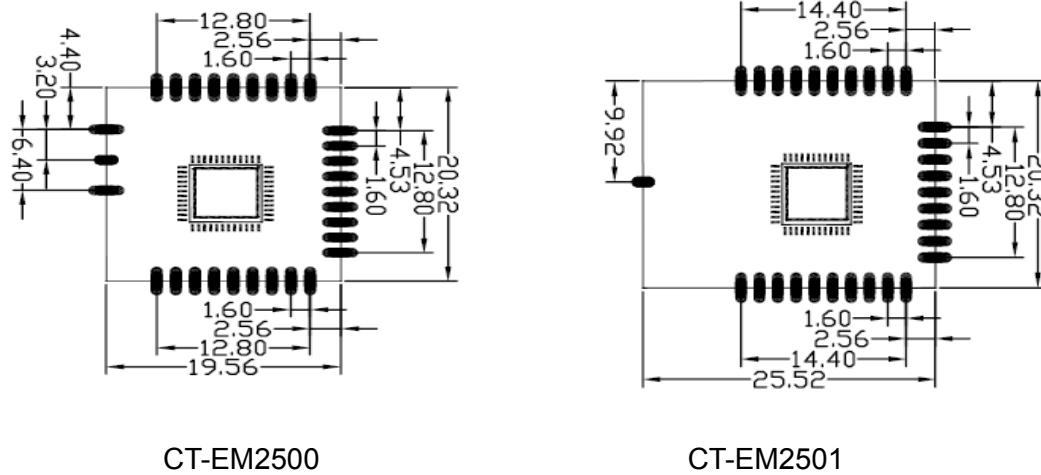

Figure 4 Mechanical Dimensions of CT-EM2500 and CT-EM2501 modules

Ordering Information

Ordering Number	Part	Description
CT-EM2500		ZigBee-ready RF module, 128 KB Flash , external antenna
CT-EM2501		ZigBee-ready RF module, 128 KB Flash, integrated antenna

Document Revision History

Document Revision	change
1.0	Draft